

Distinguishing Features of Reactions of 2-Chloro- and 2,2-Dichloro(bromo)vinyl Ketones with Alkyl- and Arylhydrazines

G. V. Bozhenkov, V. A. Savosik, L. I. Larina, L. V. Klyba, E. R. Zhanchipova,
A. N. Mirskova, and G. G. Levkovskaya

Faworsky Irkutsk Institute of Chemistry, Siberian Branch, Russian Academy of Sciences, Irkutsk, 664033 Russia
e-mail: ggl@irioc.irk.ru

Received January 5, 2008

Abstract—2-Chlorovinyl alkyl ketones react with alkylhydrazines to give mixtures of 1-R-3-R'- and 1-R-5-R'-pyrazoles: The 1-R-3-R'-pyrazoles form through the heterocyclization of 2-chlorovinyl ketone alkylhydrazones whereas in the heterocyclization into 1-R-5-R'-pyrazoles *N*¹-alkyl-*N*²-(2-acylvinyl)hydrazines are involved. The regiospecific heterocyclization of 2-chloro- and 2,2-dichlorovinyl ketones with arylhydrazines and also of 2,2-dichloro(bromo)vinyl trifluoromethyl ketones with C alkylhydrazines into pyrazoles and 5-chloro(bromo)-pyrazoles proceeds through a stage of haloenones hydrazones formation. The study of the structure of the obtained 1-alkyl-3(5)-alkylpyrazoles by means of two-dimensional ¹H and ¹³C NMR spectroscopy and GC-MS method made it possible to assign the proton and carbon signals of isomeric pyrazoles and to establish the diagnostic ions for the pair of 1,3- and 1,5-isomers.

DOI: 10.1134/S1070428008070129

Reactions of chlorovinyl alkyl ketones with hydrazine, alkyl- and arylhydrazines constitute a known method of preparation of 1-unsubstituted 3-alkylpyrazoles and 1-aryl-(alkyl)-3-alkylpyrazoles, members of an important class of compounds widely used as semiproducts in synthesis of dyes, materials for optoelectronics, pesticides, pharmaceuticals, etc. [1–3]. In these reaction the formation of two isomers was not observed.

In this study we established for the first time that in the reaction of 2-chlorovinyl propyl ketone with alkyl-

and benzylhydrazines in alcohols at heating in the presence both of acids or bases (excess hydrazine could operate as the latter) formed a mixture of two 1-R-5- and 1-R-3-propylpyrazoles in a ratio 1:2 (by ¹H NMR data). These findings suggest different paths of the isomers formation.

We believe that the formation of the mixture of pyrazole isomers is due to two competitive pathways of the reaction between 2-chlorovinyl ketones and alkylhydrazines: Along the first route 1-R-3-propyl-pyrazoles

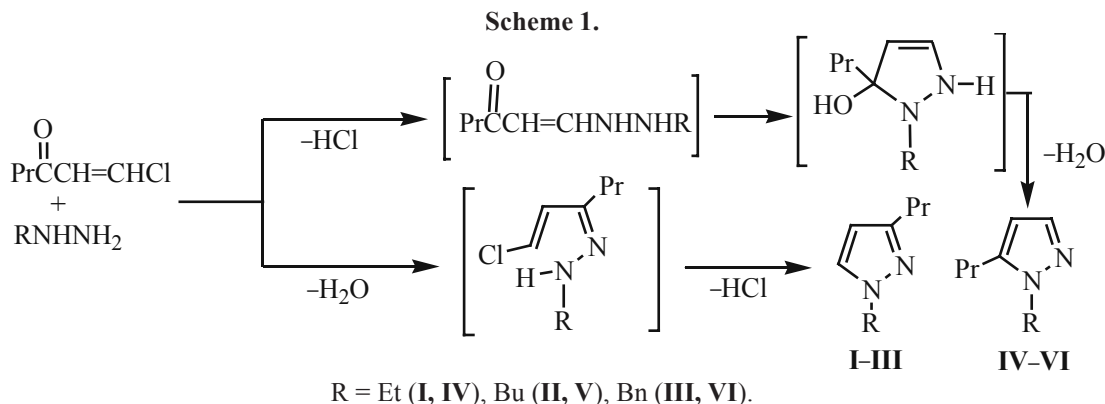

I–III form via the heterocyclization of the initially arising corresponding 2-chlorovinyl ketones alkyhydrazones; the second route consists in the heterocyclization of N^1 -alkyl- N^2 -(2-acylvinyl)-hydrazines into 1-R-5-propylpyrazoles **IV–VI** (Scheme 1).

The formation of N^1 -alkyl- N^2 -(2-acylvinyl)hydrazines occurs probably by a nucleophilic addition of alkyl-(benzyl)hydrazines to a butanoylacetylene, the dehydrochlorination product of propyl 2-chlorovinyl ketone. Besides in the reaction of the nucleophilic substitution of a halogen atom in the haloenone and in the addition to the acetylene ketone may act the hydrochloride of the hydrazine; as a result in the process would be involved the more nucleophilic NH_2 group and not $\text{N}^+\text{H}_2\text{RCl}^-$. On the other hand, N^1 -alkyl- N^2 -(2-acyl-vinyl)hydrazines might arise by an intramolecular rearrangement of the preliminary formed hydroxyalkylhydrazines (Scheme 2).

The structure of compounds **I–VI** was investigated by ^1H and ^{13}C NMR spectroscopy and GC-MS method, their composition was confirmed by elemental analysis.

Chemical shifts of protons in the position 4 are virtually alike in the spectra of 3- and 5-alkylpyrazoles **I–VI**, whereas the signal of the H^5 proton of 3-alkylpyrazoles is shifted upfield as compared with the corresponding signals of H^3 proton of 5-alkylpyrazoles.

The analysis of two-dimensional ^1H and ^{13}C NMR spectra of the mixture of 1-alkyl-3-propylpyrazoles and 1-alkyl-5-propylpyrazoles **I–VI** [4–6] made it possible to establish their structure and to assign the proton signals in the positions 3, 4 and 4, 5 of the pyrazole ring.

In the NOESY spectra of the mixture of 1-ethyl-3-propylpyrazole (**I**) and 1-ethyl-5-propylpyrazole (**IV**) a cross-peak was observed for the CH_2 moiety of ethyl and propyl groups in the positions 1 and 5 of the pyrazole ring. The assignment of the carbon signals was based on the 2D spectra HMBC ^1H - ^{13}C and HSQC ^1H - ^{13}C .

In the ^{15}N NMR spectra of 1-ethyl-3-propylpyrazole (**I**) and 1-ethyl-5-propylpyrazole (**IV**) the signals of the pyridine atom ^{15}N appear in the region -76.5 ppm, and the signals of the pyrrole nitrogen atom, in the regions -164.5 and -166.5 ppm respectively.

A characteristic feature of the mass spectra of 1-alkyl-3(5)-propylpyrazoles **I–VI** is the presence of an intensive peak of the molecular ion whose fragmentation occurs in accordance with the rules established for the decomposition of pyrazoles [7]. The position of the propyl substituent in 1-butylpyrazoles **II** and **V** virtually does not affect the fragmentation route to one of the main fragment ions with m/z 123 (I_{rel} 100, 90%) resulting

Scheme 2.

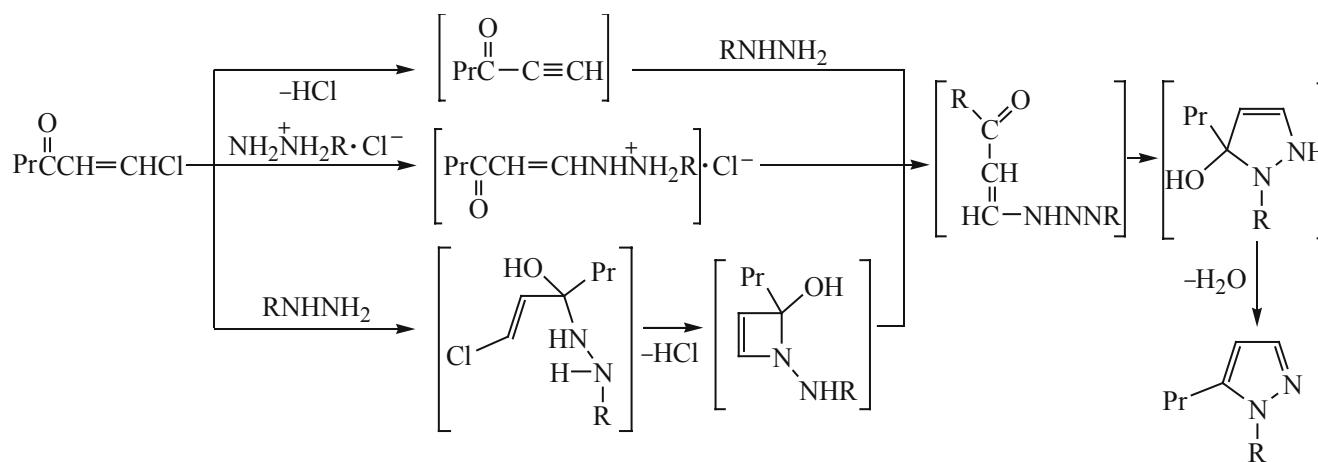

Scheme 3.

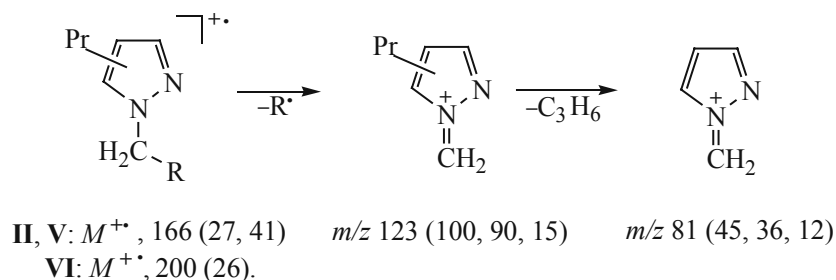

Scheme 4.

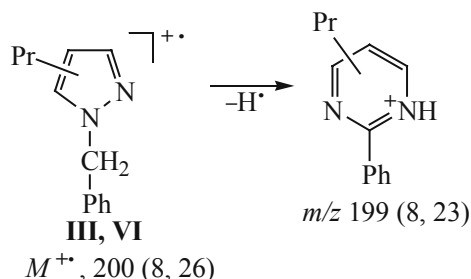

from the elimination of the maximal alkyl radical [8] (Scheme 3).

In the mass spectra of two 1-benzyl pyrazole derivatives **III** and **VI** ion with m/z 123 (15%) $[M - C_3H_7]^+$ was observed only in the spectrum of 1,5-substituted pyrazole **VI**. For these compounds as expected the most abundant peak belonged to tropylium ion $[C_7H_7]^+$, m/z 91 (100%) [7]. Besides compounds **III** and **VI** were characterized by the appearance of an ion $[M - H]^+$ (Scheme 4). Like in methylbenzylpyrazoles [7] the hydrogen atom evidently was abstracted from the bridging methylene group between pyrazole and benzene rings.

Another general direction of M^{+} decomposition of compounds **II** and **V** insensitive to the position of the substituent is due to Mc Lafferty rearrangement [9] (Scheme 5).

Despite the close resemblance of the mass spectra of these isomeric pairs essential difference exists making

Scheme 5.

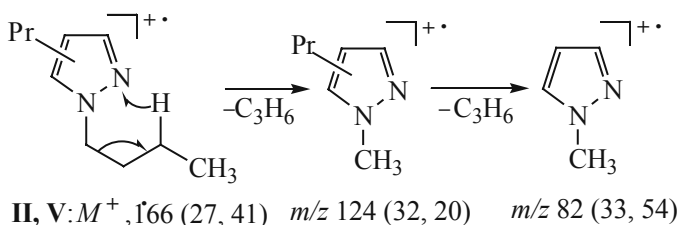

Scheme 6.

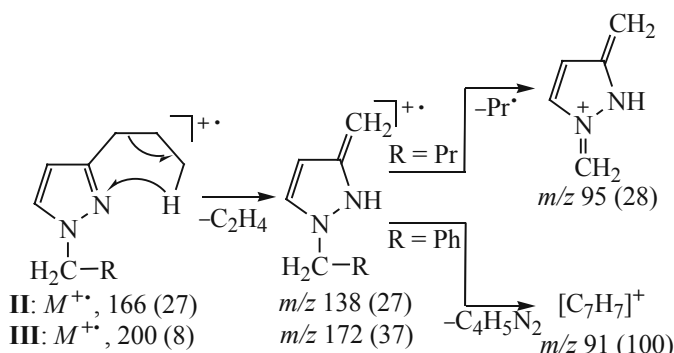

Scheme 7.

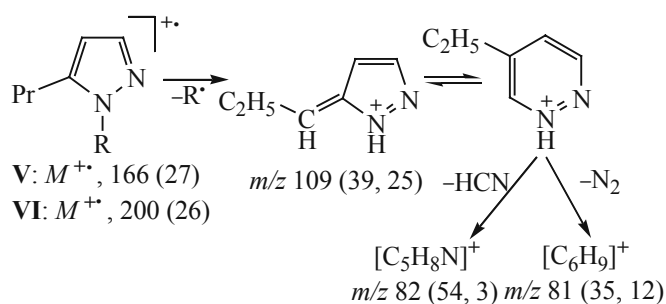

Scheme 8.

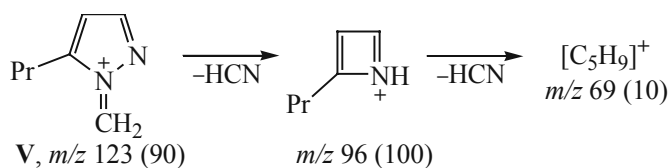

possible an unambiguous identification of 1,3- and 1,5-isomers.

For instance, the elimination of ethylene molecule from the M^{+} of pyrazoles **II** and **III** by the mechanism of Mc Lafferty rearrangement [9] proves the location of propyl substituent in the position 3 of the pyrazole ring (Scheme 6). This path of fragmentation is absent in the mass spectra of pyrazoles **V** and **VI**.

On the other hand, exclusively in the mass spectra of 5-propyl-substituted pyrazoles **V** and **VI** the M^{+} suffered fragmentation with the rupture of the C–N bond and the formation of a diagnostic ion $[M - R]^+$, m/z 109 (Scheme 7).

Besides 1-butyl-5-propylpyrazole (**V**) easily loses HCN molecule from the ion $[M - C_3H_7]^+$ of m/z 123 providing an ion of m/z 96, whose peak in the mass spectrum is the most abundant (Scheme 8). This fragmentation is impossible for 1-butyl-3-propylpyrazole (**II**).

Thus the appearance of diagnostic ions for each isomeric pair permits unambiguous identification of the structure by means of mass spectra.

In contrast to the observed formation of the mixture of 1,3- and 1,5-substituted pyrazoles in the reaction of 2-chlorovinyl ketones with alkyldiazines we formerly [10–12] established that in the similar reaction of 1,2- and 2,2-dichlorovinyl ketones with alkyldiazines occurred a chemoselective formation solely of 1,3-diorganyl-substituted 4(5)-chloropyrazoles.

In this study the latter fact was once more proved by an example of reactions of trifluoromethyl 2,2-dichloro-

(bromo)vinyl ketones with ethyl- and benzylhydrazine. Therewith under the conditions similar to the preparation of mixtures of 1,3- and 1,5-substituted pyrazoles **I–VI** from the 2-chlorovinyl alkyl ketones with alkylhydrazines the trifluoromethyl-2,2-dihaloenones and ethyl(benzyl)hydrazines chemoselectively provided previously unknown 1-ethyl(benzyl)-3-trifluoromethyl-substituted 5-chloro(bromo)pyrazoles **VII–X**.

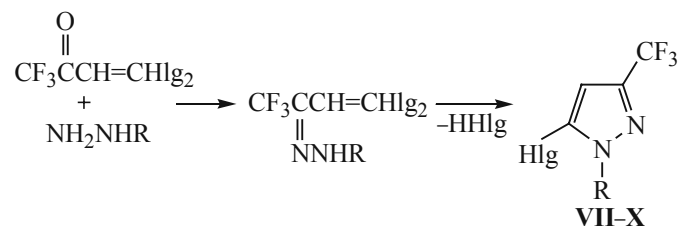

R = Et, Hlg = Cl (**VII**), Br (**VIII**); R = Bn, Hlg = Cl (**IX**), Br (**X**).

Evidently here proceeded the heterocyclization of the initially formed alkyldiazones of the haloenones into the corresponding 5-halo-1-alkylpyrazoles. However we failed to isolate the corresponding individual diazones under these conditions or at their variation.

An alternative reaction mechanism involving primary formation of 1-(1-halo-2-acylvinyl)-1-alkylhydrazine halides followed by heterocyclization into pyrazoles we regard as hardly probable since it is known that 1-[1-bromo-2-benzoyl(2-thienyl)vinyl]-1,1-dimethylhydrazine bromides obtained from the corresponding bromoethynyl phenyl(thienyl-2) ketones and 1,1-di-methylhydrazine whose structure has been established by XRD study fail to undergo cyclization into pyrazoles [13].

Yet 2,2-difluoro-1-alkylvinyl phenyl(cyclohexyl) ketones react with the monosubstituted alkyl(aryl)hydrazines giving 1-alkyl-(aryl)-3-phenyl(cyclohexyl)-4-alkyl-5-fluoropyrazoles [14]. Ichikava et al. believe that the reaction mechanism consisted in the initial replacement of the fluorine atom followed by the intramolecular heterocyclization of the arising 1-alkyl-(aryl)-1-(1-fluoro-2-acyl-2-alkylvinyl)hydrazines into pyrazolines whose dehydration led to the target pyrazoles.

In the present study we proved that the reactions of 2-chloro-, 1,2- and 2,2-dichlorovinyl ketones and of dichloroacroleine with 1-phenyl- and 4-nitrophenylhydrazine proceeded with primary formation of the corresponding aryldiazones **XI–XX** that were for the first time isolated, characterized, or revealed by NMR spectroscopy in the reaction mixture. These diazones were converted in good yield into 1-aryl-3-R-pyrazoles **XXI–XXIX**.

A chemoselective synthesis gave in good yield pyrazoles **XXII–XXIX** by heating in acid medium preliminary prepared aryldiazones **XI–XXI**, among them the previously described chloromethyl 2,2-dichlorovinyl ketone 2,4-dinitrophenylhydrazine [15] (Scheme 9).

1-Arylpyrazoles **XXII–XXVIII** were also obtained in quantitative yields in one-pot procedure by heating a mixture of aryldiazones and halovinyl ketones in the presence of acids. Here no isomeric 1-aryl-5-R-pyrazole was obtained. This fact is evidently due to the lower basicity of aryldiazones that results in their inability to nucleophilic addition-replacement of the halogen atom in the haloenones.

Scheme 9.

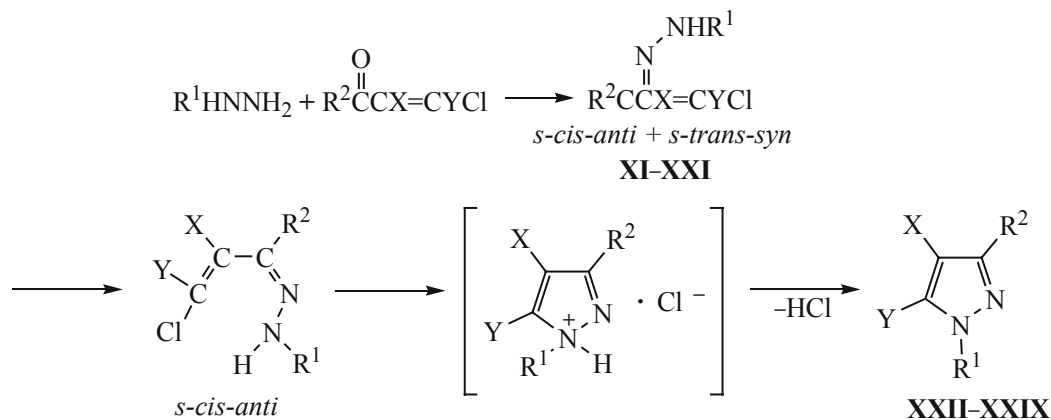

R¹ = Ph: X = Y = H, R² = Me (**XI**, **XXII**), Pr (**XII**); X = H, Y = Cl, R² = CF₃ (**XIII**, **XXIII**); X = Cl, Y = H, R² = Me (**XIV**, **XXIV**), C₃H₇ (**XV**, **XXV**); R¹ = 4-O₂NC₆H₄: X = Y = H, R² = Me (**XVI**, **XXVI**); X = H, Y = Cl, R² = H (**XVII**, **XXVIII**), Pr (**XVIII**), Ph (**XIX**); X = Cl, Y = H, R² = Et (**XX**), Pr (**XXI**); R¹ = 2,4-(O₂N)₂C₆H₃, X = H, Y = Cl, R² = CH₂Cl (**XXIX**).

The addition of acid to the reaction mixture favors the conversion of arylhydrazones into *syn*-isomers readily undergoing cyclization into pyrazoles. In the course of the heterocyclization of the 2,2-dichlorovinyl ketones 2,4-dinitrophenylhydrazones the *syn-anti* isomerism plays the governing role: Dinitrophenylhydrazones of aliphatic ketones exist mainly in the *anti*-form, dinitrophenylhydrazones of aromatic ketone, in the *syn*-form facilitating the intramolecular heterocyclization [15–17]. The energy barrier of the transition between the forms is relatively high [15], but as previously found [16] the *syn-anti* conversion of the geometric isomers of hydrazones is catalyzed by acids.

On the other hand the probable role of acid in the heterocyclization of halovinyl ketones hydrazones consists in the electrophilic activation of the nucleophilic substitution. Thus the acid protonates the amidine nitrogen, the effect is transferred along the system of the conjugated bonds resulting in the increase in the electrophilicity of the β -carbon of the double bond, and it facilitates the nucleophilic attack of the amine nitrogen on the carbon of the double bond.

Considering the experimental findings obtained it may be concluded that 2-chlorovinyl ketones arylhydrazones are already in the geometric form required for the heterocyclization, or the energy barrier to the transition between the configuration is far less than in 2,2-dichlorovinyl ketones 2,4-dinitrophenylhydrazones [15, 16]. For instance, already at the preparation of methyl-2-chlorovinylketone arylhydrazones **XI** and **XVI** under optimum conditions without heating the corresponding pyrazoles **XXII** and **XXVI** form as impurity.

In the IR spectra of obtained hydrazones and pyrazoles **XI–XXIX** characteristic absorption bands are observed from the bonds C–H_{Alk}, N–H, =C–H, C=N, C=C, and in the spectra of hydrazones **XVI–XXI** and pyrazoles **XXVI–XXIX**, also of NO₂ groups. The IR spectra of pyrazoles synthesized lack the strong absorption band in the region 3300 cm⁻¹ belonging to the vibrations of NH in the initial hydrazones, and contain a new band in the region 3145–3150 cm⁻¹ characteristic of the stretching vibrations of =C⁴–H and =C⁵–H of the heterocycle.

In the ¹H NMR spectra of hydrazones **XI–XX** the protons of NH group and of CH of the halovinyl group give rise to singlets indicating that the compounds exist as single geometric isomers and analogously to the structure of alkyl 2,2-dichlorovinyl ketones dinitrophenylhydrazones presumably in the *anti*-form. The ¹H NMR spectrum of phenyl 2,2-dichlorovinyl ketone 4-nitro-

phenylhydrazone (**XIX**) contains two pairs of singlets belonging to these protons indicating that the substance exists as a mixture of *syn*- and *anti*-isomers like the phenyl 2,2-dichlorovinyl ketone 2,4-dinitrophenylhydrazone [16].

In the ¹H NMR spectra of the obtained pyrazoles the signals of protons H⁴ appear in the region 5.9–6.5 ppm, and the signals of protons H⁵, at 7.40–8.45 ppm.

It is therefore established that alkyl 2-chlorovinyl ketones react with alkyl(benzyl)hydrazines to provide a mixture of 1,3- and 1,5-substituted pyrazoles, whereas 2,2-dihalovinyl ketones in the similar reaction chemoselectively form 1,3-disubstituted 5-halopyrazoles. A chemo-selective formation of 1-arylpyrazoles also occurs in reactions of 2-halo-, 2,2-dihaloenones and arylhydrazines that undeniably makes these compounds accessible and interesting objects of further research. The employing in the pyrazole synthesis of alkyl(aryl) 2-chloro- and 2,2-dichlorovinyl ketones and alkyl-, arylhydrazines permits extensive variation both of the structure and position of the substituents in the ring, and also of the presence and position of chlorine in pyrazoles.

EXPERIMENTAL

IR spectra were recorded on a spectrophotometer Specord 75IR from pellets with KBr or in thin film. ¹H, ¹³C, and ¹⁵N NMR spectra of compounds obtained were registered on spectrometers Bruker DPX-400 and Bruker AV-400 (400.13, 100.62, and 40.56 MHz respectively).

Chemical shifts of ¹H and ¹³C were measured from tetramethylsilane with an accuracy of 0.01 and 0.02 ppm respectively. Coupling constants J_{CH} were measured with an accuracy of 0.1 Hz. The carbon signals were assigned using 2D heteronuclear NMR spectroscopy HSQC-GP ¹H–¹³C [4], the quaternary carbon signals were assigned with the help of 2D heteronuclear NMR spectroscopy HMBC-GP ¹H–¹³C [5]. HSQC-GP: matrix size 2Q × 1Q, ¹H spectrum width 2000 Hz, ¹³C spectrum width 6000 Hz, relaxation delay 2 s. Before the Fourier transform the signal of free induction decay was multiplied by a bell function with a zero shift.

HMBC-GP: matrix size 2Q × 1Q, ¹H spectrum width 2000 Hz, ¹³C spectrum width 6000 Hz, relaxation delay 2 s. Parameter of pulse sequence were selected for averaged coupling constants values ¹ J_{CH} and ⁿ J_{CH} . Before the Fourier transform the signal of free induction decay was multiplied by a bell function with a zero shift.

Chemical shifts in ^{15}N NMR spectrum were measured with an accuracy of 0.1 ppm (relative to the external reference $\text{CH}_3^{15}\text{NO}_2$) applying 2D heteronuclear NMR spectroscopy HMBC-GP ^1H - ^{15}N .

2D ^1H - ^1H -NMR spectra were obtained by NOESY procedure using a standard program NOESYTP in the phase-sensitive version [6], matrix size 2Q \times 1Q, spectrum width 3000 Hz. The mixing period was adjusted for each sample and amounted from 0.2 to 2 s.

Mass spectra of electronic ionization (70 eV) of compounds **I**–**VI** were measured on a Shimadzu GCMS-QP5050A instrument (quadrupole mass analyzer, the range of detected masses 34–650 D). The chromatographic separation of compounds under study was performed on a capillary column SPB-5 (60 m \times 0.25 mm \times 0.25 μm), carrier gas helium, flow rate 0.7 ml/min. For 1-butyl-3(5)-propylpyrazoles (**II**, **V**) the temperature of vaporizer and ion source 220 $^\circ\text{C}$, pressure 100 kPa; ramp from 60 to 220 $^\circ\text{C}$ at a rate 8 deg/min. For 1-benzyl-3(5)-propylpyrazoles (**III**, **VI**) temperature of vaporizer and ion source 250 $^\circ\text{C}$, pressure 280 kPa; ramp from 70 to 250 $^\circ\text{C}$ at a rate 10 deg/min. The samples of 1 μl were chaged in the mode of flow division 1:2.

3-Propyl-1-ethylpyrazole (I) and 5-propyl-1-ethylpyrazole (IV). *a.* To a solution of 0.60 g (0.01 mol) of ethylhydrazine in 15 ml of ethanol was slowly added dropwise 1.33 g (0.01 mol) of 2-chlorovinyl propyl ketone and 1 ml of acetic acid. The reaction mixture was boiled for 3 h, then cooled and poured into water. The product was extracted into ethyl ether, the ether extract was dried with CaCl_2 and distilled. Yield of pyrazoles **I** and **IV** mixture in the ratio 2:1 1 g (60%), bp 78–84 $^\circ\text{C}$ (8 mm Hg).

b. To a solution of 1.33 g (0.01 mol) of 2-chlorovinyl propyl ketone in 15 ml of ethanol was slowly added 0.60 g (0.01 mol) of ethylhydrazine and 1.01 g (0.01 mol) of triethylamine. The reaction mixture was stirred for 5 h and left overnight. Further workup was the same as in procedure *a*. Yield 0.85 g. IR spectrum, ν , cm^{-1} : 3080 (=CH); 2960, 2930, 2875 (Alk); 1680, 1580 (C=N, C=C). ^1H NMR spectrum (CDCl_3), δ , ppm: 7.41 d (H^3 , J 1.6 Hz), 7.27 d (H^5 , J 2.0 Hz), 6.01 d.d (1H, H^4 , J 1.6, J 2.0 Hz), 4.09 m (2H, CH_2N , J 7.2 Hz), 2.58 m (2H, CH_2 , J 7.2 Hz), 1.68 m (2H, CH_2 , J 7.2 Hz) 1.43 m (3H, CH_3 , J 7.2 Hz), 0.98 (3H, CH_3 , J 7.2 Hz). ^{13}C NMR spectrum (CDCl_3), δ , ppm: 152.57, 141.62, 137.78, 128.40, 103.66, 103.42, 46.25, 43.31, 30.18, 27.15, 22.93, 22.70, 21.79 (CH_2), 15.41, 15.30 (CH_3), 13.69, 13.59.

Found, %: C 69.50; H 10.02; N 20.21. $\text{C}_8\text{H}_{14}\text{N}_2$. Calculated, %: C 69.52; H 10.21; N 20.27.

1-Butyl-3-propylpyrazole (II) and 1-butyl-5-propylpyrazole (V) were obtained by procedure *b* from 0.88 g (0.01 mol) of butylhydrazine and 1.33 g (0.01 mol) of 2-chlorovinyl propyl ketone. Yield 1.16 g, ratio **II**:**V** = 5:2, bp 83–85 $^\circ\text{C}$ (12 mm Hg). IR spectrum, ν , cm^{-1} : 3080 (=CH); 2960, 2930, 2875 (Alk); 1680, 1580 (C=N, C=C). ^1H NMR spectrum (CDCl_3), δ , ppm: 7.45 d (H^3 , J 1.6 Hz), 7.27 d (H^5 , J 2.0 Hz), 6.04 d (H^4 , J 2.0 Hz), 5.96 d (H^4 , J 1.6 Hz), 4.09 m (2H, CH_2N , J 7.2 Hz), 2.63, 2.56, 1.77, 1.65, 1.29 m (8H, 4 CH_2 , J 7.2 Hz), 0.93 m (6H, 2 CH_3 , J 7.2 Hz). Found, %: C 72.28; H 10.35; N 16.62. $\text{C}_{10}\text{H}_{18}\text{N}_2$. Calculated, %: C 72.24; H 10.91; N 16.85.

1-Benzyl-3-propylpyrazole (III) and 1-benzyl-5-propylpyrazole (VI) were obtained by procedure *a* from 1.22 g (0.01 mol) of benzylhydrazine, 1.33 g (0.01 mol) of 2-chlorovinyl propyl ketone, and 0.5 ml of acetic acid. Yield 1.30 g, ratio **III**:**VI** = 2:1, undistillable oily liquid. IR spectrum, ν , cm^{-1} : 3080 (=CH); 2960, 2930, 2875 (Alk); 1680, 1580 (C=N, C=C). ^1H NMR spectrum (CDCl_3), δ , ppm: 7.25 d (H^3 , J 16.7 Hz), 7.23, 7.03 m (6H, H^5 , Ph), 6.04 d, 6.09 d (1H, H^4 , J 1.6, J 2.2 Hz), 5.27 s (2H, CH_2N), 2.61 m (2H, CH_2 , J 7.2 Hz), 1.53 m (2H, CH_2 , J 7.2 Hz), 0.92 m (3H, CH_3 , J 7.2 Hz). Found, %: C 77.90; H 8.00; N 14.01. $\text{C}_{13}\text{H}_{16}\text{N}_2$. Calculated, %: C 77.96; H 8.05; N 13.99.

3-Trifluoromethyl-5-chloro-1-ethylpyrazole (VII). To a solution of 1.93 g (0.01 mol) of 2,2-dichlorovinyl trifluoromethyl ketone in 30 ml of ethanol was added dropwise 0.60 g (0.01 mol) ethylhydrazine and 1.01 g (0.01 mol) of triethylamine. The reaction mixture was boiled for 3 h, cooled, and poured into water. The product was extracted into ethyl ether, the ether extract was dried with CaCl_2 and distilled. Yield 1.48 g (74%), bp 158–160 $^\circ\text{C}$, n_D^{20} 1.4235. IR spectrum, ν , cm^{-1} : 3150 (=CH); 2985, 2950, 2900, 2875 (Alk); 1550 (C=N, C=C). ^1H NMR spectrum (CDCl_3), δ , ppm: 6.44 (1H, H^4), 4.21 q (2H, CH_2 , J 7.3 Hz), 1.43 t (3H, CH_3 , J 7.3 Hz). ^{13}C NMR spectrum (CDCl_3), δ , ppm: 142.86 q (C^3 , $J_{\text{C-F}}$ 39.1 Hz), 127.73 (C^5), 120.69 q (CF_3 , $J_{\text{C-F}}$ 286.3 Hz), 103.25 q (C^4 , $J_{\text{C-F}}$ 2.3 Hz), 45.09 (CH_2), 14.60 (CH_3). Found, %: C 36.15; H 3.02; Cl 17.83; F 28.72; N 14.05. $\text{C}_6\text{H}_6\text{ClF}_3\text{N}_2$. Calculated, %: C 36.29; H 3.05; Cl 17.85; F 28.70; N 14.11.

5-Bromo-3-trifluoromethyl-1-ethylpyrazole (VIII) was similarly obtained from 2.82 g (0.01 mol) of 2,2-dibromovinyl trifluoromethyl ketone, 0.60 g (0.01 mol) of

ethylhydrazine, and 1.01 g (0.01 mol) of triethylamine. Yield 1.18 g (49%), bp 58–60°C, n_D^{20} 1.4425. IR spectrum, ν , cm^{-1} : 3150 (=CH); 2995, 2950, 2900, 2880 (Alk); 1575 (C=N, C=C). ^1H NMR spectrum (CDCl_3), δ , ppm: 6.52 (1H, H⁴), 4.22 q (2H, CH₂, J 7.3 Hz), 1.44 t (3H, CH₃, J 7.3 Hz). ^{13}C NMR spectrum (CDCl_3), δ , ppm: 142.63 q (C³, $J_{\text{C-F}}$ 39.1 Hz), 127.73 (C⁵), 120.69 q (CF₃, $J_{\text{C-F}}$ 286.3 Hz), 107.03 q (C⁴, $J_{\text{C-F}}$ 2.3 Hz), 46.33 (CH₂), 14.85 (CH₃). Found, %: C 29.45; H 2.33; Br 31.07; F 22.13; N 16.30. C₆H₆BrF₃N₂. Calculated, %: C 29.65; H 2.49; Br 31.09; F 22.17; N 16.35.

1-Benzyl-3-trifluoromethyl-5-chloropyrazole (IX) was similarly obtained from 1.93 g (0.01 mol) of 2,2-dichlorovinyl trifluoromethyl ketone, 1.22 g (0.01 mol) of benzylhydrazine, and 1.01 g (0.01 mol) of triethylamine. Yield 1.58 g (61%), bp 130–132°C (12 mm Hg). IR spectrum, ν , cm^{-1} : 3145, 3090, 3070, 3030 (=CH); 2975, 2950 (CH₂); 1600, 1575, 1545 (C=N, C=C). ^1H NMR spectrum (CDCl_3), δ , ppm: 7.35 m, 7.28 d (5H, C₆H₅), 6.53 (1H, H⁴), 5.40 (2H, CH₂). Found, %: C 50.30; H 3.08; Cl 13.58; F 21.89; N 10.73. C₁₁H₈ClF₃N₂. Calculated, %: C 50.59; H 3.09; Cl 13.54; F 21.87; N 10.75.

1-Benzyl-5-bromo-3-trifluoromethylpyrazole (X) was similarly obtained from 2.82 g (0.01 mol) of 2,2-dibromovinyl trifluoromethyl ketone, 1.22 g (0.01 mol) of benzylhydrazine, and 1.01 g (0.01 mol) of triethylamine. Yield 2.19 g (72%), bp 130–132°C (12 mm Hg). IR spectrum, ν , cm^{-1} : 3145, 3090, 3070, 3030 (=CH); 2975, 2950 (CH₂); 1600, 1575, 1545 (C=N, C=C). ^1H NMR spectrum (CDCl_3), δ , ppm: 7.35 m, 7.26 d (5H, C₆H₅), 6.61 (1H, H⁴), 5.43 (2H, CH₂). Found, %: C 43.15; H 2.66; Br 26.20; F 18.69; N 9.19. C₁₁H₈BrF₃N₂. Calculated, %: C 43.30; H 2.64; Br 26.19; F 18.68; N 9.18.

Phenylhydrazones of halovinyl ketones. To a solution of halovinyl ketone in ethanol was slowly at stirring added dropwise at room temperature equimolar quantity of phenylhydrazine. The reaction mixture was stirred at room temperature for 2–4 h and then diluted with cold water. The separated oily dark-red substance was extracted into ether, the extract was dried with MgSO₄, filtered from the drying agent, and the solvent was removed in a vacuum. The residue consisted of the hydrazone as oily undistillable fluid.

Methyl 2-chlorovinyl ketone phenylhydrazone (XI) was obtained from 1.05 g (0.01 mol) of 2-chlorovinyl methyl ketone in 20 ml of ethanol and 1.08 g (0.01 mol) of phenylhydrazine in 2 h. The reaction product contained up to 20% of 1-phenyl-3-methylpyrazole (XXII). IR spectrum, ν , cm^{-1} : 3205 (NH), 3100,

3050 (=CH); 2950 (CH₃); 1590 (C=C). ^1H NMR spectrum (CDCl_3), δ , ppm: 7.68 d (1H, H^β, J 13.7 Hz), 7.55 d, 7.29 m (5H, C₆H₅), 6.13 d (1H, H^α, J 13.7 Hz), 2.30 (3H, CH₃). Found, %: C 61.75; H 5.68; Cl 18.24; N 14.40. C₁₀H₁₁ClN₂. Calculated, %: C 61.70; H 5.70; Cl 18.21; N 14.39.

Propyl 2-chlorovinyl ketone phenylhydrazone (XII) was obtained from 1.33 g (0.01 mol) of propyl 2-chlorovinyl ketone and 1.08 g (0.01 mol) of phenylhydrazine in 25 ml of ethanol. Yield 1.26 g (57%). IR spectrum, ν , cm^{-1} : 3250 (NH), 3100, 3050 (=CH); 2950, 2930, 2870 (C₃H₇); 1590 (C=C). ^1H NMR spectrum (CDCl_3), δ , ppm: 7.69 d (1H, H^β, J 13.3 Hz), 7.55 d, 7.29 m (5H, C₆H₅), 6.18 d (1H, H^α, J 13.3 Hz), 2.70 t (2H, CH₂, J 7.2 Hz), 1.76 m (2H, CH₂), 1.01 t (3H, CH₃, J 7.2 Hz). Found, %: C 65.20; H 6.29; Cl 15.97; N 12.62. C₁₂H₁₄ClN₂. Calculated, %: C 65.01; H 6.36; Cl 15.99; N 12.64.

2,2-Dichlorovinyl trifluoromethyl ketone phenylhydrazone (XIII) was obtained from 1.93 g (0.01 mol) of trifluoromethyl 2,2-dichlorovinyl ketone and 1.08 g (0.01 mol) of phenylhydrazine in 25 ml of ethanol in 4 h. Yield 1.23 g (54%). IR spectrum, ν , cm^{-1} : 3300 (NH); 3140, 3060 (=CH); 1590 (C=C). ^1H (CDCl_3), δ , ppm: 7.50 m, 7.44 m (5H, C₆H₅), 6.63 (1H, H^α). Found, %: C 40.89; H 2.60; Cl 25.00; F 19.97; N 9.84. C₁₀H₇Cl₂F₃N₂. Calculated, %: C 42.43; H 2.49; Cl 25.05; F 20.13; N 9.90.

1,2-Dichlorovinyl methyl ketone phenylhydrazone (XIV) was obtained from 1.39 g (0.01 mol) of methyl 1,2-dichlorovinyl ketone and 1.08 g (0.01 mol) of phenylhydrazine in 20 ml of ethanol. Yield 1.6 g (70%). IR spectrum, ν , cm^{-1} : 3340 (NH); 3130, 3055 (=CH); 2960, 2920 (CH₃); 1597 (C=C). ^1H NMR spectrum (CDCl_3), δ , ppm: 7.78 (1H, H^β), 7.45 m (5H, C₆H₅), 2.35 (3H, CH₃). Found, %: C 52.40; H 4.45; Cl 30.80; N 12.32. C₁₀H₁₀Cl₂N₂. Calculated, %: C 52.42; H 4.40; Cl 30.95; N 12.23.

1,2-Dichlorovinyl propyl ketone phenylhydrazone (XV) was obtained from 1.67 g (0.01 mol) of propyl 1,2-dichlorovinyl ketone and 1.08 g (0.01 mol) of phenylhydrazine in 20 ml of ethanol. Yield 1.8 g (70%). IR spectrum, ν , cm^{-1} : 3300 (NH); 3130, 3050 (=CH); 2955, 2930, 2875 (C₃H₇); 1595 (C=C). ^1H NMR spectrum (CDCl_3), δ , ppm: 7.80 s (1H, H^β), 7.41 m (5H, C₆H₅), 2.70 t (2H, CH₂, J 7.2 Hz), 1.76 m (2H, CH₂), 1.01 t (3H, CH₃, J 7.2 Hz). Found, %: C 56.00; H 5.46; Cl 27.53; N 10.86. C₁₂H₁₄Cl₂N₂. Calculated, %: C 56.05; H 5.49; Cl 27.57; N 10.89.

4-Nitrophenylhydrazones of halovinyl ketones. To a solution of 1.53 g (0.01 mol) of 4-nitrophenylhydrazine and 0.5 ml of H_2SO_4 in 40 ml of ethanol was slowly at stirring added dropwise at room temperature an equimolar quantity of halovinyl ketone. The reaction mixture was stirred for 4 h at room temperature, then it was diluted with cold water, the separated precipitate was filtered off, washed with water, and dried.

Methyl 2-chlorovinyl ketone 4-nitrophenylhydrazone (XVI) was obtained from 1.05 g (0.01 mol) of methyl 2-chlorovinyl ketone and 1.53 g (0.01 mol) of 4-nitrophenylhydrazine. The precipitate consisted of hydrazone XVI and 1-(4-nitrophenyl)-3-methylpyrazole (XXVI) in the ratio 1:1, mp 165–166°C. IR spectrum, ν , cm^{-1} : 3300 (NH); 3050 (=CH); 2960 (CH_3); 1600 (C=N); 1585 (C=C); 1540, 1330 (NO_2). 1H NMR spectrum (DMSO- d_6), δ , ppm: 10.18 (NH), 8.33 d (2H, $H^{3',5'}$, J 9.0 Hz), 8.11 d (2H, $H^{2',6'}$, J 9.0 Hz), 6.98 d (1H, H^b , J 13.7 Hz), 6.62 d (1H, H^a , J 13.7 Hz), 2.30 c (3H, CH_3).

β,β -Dichloroacrolein 4-nitrophenylhydrazone (XVII) was obtained from 1.25 g (0.01 mol) of β,β -dichloroacrolein and 1.53 g (0.01 mol) of 4-nitrophenylhydrazine. Yield 2.52 g (97%), mp 207–208°C. IR spectrum, ν , cm^{-1} : 3250 (NH); 3150, 3100, 3070 (=CH); 1600 (C=N); 1580 (C=C); 1550, 1305 (NO_2). 1H NMR spectrum (DMSO- d_6), δ , ppm: 11.43 (1H, NH), 8.10 d (2H, $H^{3',5'}$, J 9.3 Hz), 7.79 d (1H, H_{abd} , J 8.9 Hz), 7.05 d (2H, $H^{2',6'}$, J 9.3 Hz), 6.84 d (1H, H^a , J 8.9 Hz). Found, %: C 47.56; H 2.71; Cl 30.26; N 18.16. $C_9H_7Cl_2N_3O_2$. Calculated, %: C 47.58; H 3.11; Cl 30.81; N 18.51.

Propyl 2,2-dichlorovinyl ketone 4-nitrophenylhydrazone (XVIII) was obtained from 1.67 g (0.01 mol) of 2,2-dichlorovinyl propyl ketone and 1.53 g (0.01 mol) of 4-nitrophenylhydrazine. Yield 2.87 g (95%), mp 115–117°C. IR spectrum, ν , cm^{-1} : 3300 (NH); 3030 (=CH); 2950, 2920, 2870 (C_3H_7); 1600 (C=N); 1585 (C=C); 1550, 1310 (NO_2). 1H NMR spectrum (DMSO- d_6), δ , ppm: 10.32 s (1H, NH), 8.09 d (2H, $H^{3',5'}$, J 7.3 Hz), 7.28 d (2H, $H^{2',6'}$, J 7.3 Hz), 6.71 s (1H, H^4), 2.46 t (2H, CH_2 , J 7.2 Hz), 1.46 m (2H, CH_2 , J 7.2 Hz), 0.91 t (3H, CH_3 , J 7.2 Hz). Found, %: C 43.83; H 4.35; Cl 23.23; N 13.95. $C_{12}H_{13}Cl_2N_3O_2$. Calculated, %: C 47.80; H 4.32; Cl 23.22; N 13.94.

Phenyl 2,2-dichlorovinyl ketone 4-nitrophenylhydrazone (XIX) was obtained from 2.01 g (0.01 mol) of 2,2-dichlorovinyl phenyl ketone and 1.53 g (0.01 mol) of 4-nitrophenylhydrazine. Yield 3.23 g (96%), mp 94–

139°C. IR spectrum, ν , cm^{-1} : 3300 (NH); 3115, 3070 (=CH); 1585 (C=C); 1550, 1305 (NO_2). 1H NMR spectrum (DMSO- d_6), δ , ppm: 10.64, 10.11 (NH), 8.17 d (2H, $H^{3',5'}$, J 9.2 Hz), 7.44 d (2H, $H^{2',6'}$, J 9.2 Hz), 7.13, 6.91 s (1H, H^4). Found, %: C 53.59; H 3.30; Cl 21.09; N 12.50. $C_{15}H_{11}Cl_2N_3O_2$. Calculated, %: C 53.58; H 3.28; Cl 21.08; N 12.48.

Ethyl 1,2-dichlorovinyl ketone 4-nitrophenylhydrazone (XX) was obtained from 1.53 g (0.01 mol) of 1,2-dichlorovinyl ethyl ketone and 1.53 g (0.01 mol) of 4-nitrophenylhydrazine. Yield 2.66 g (97%), mp 122–123°C. IR spectrum, ν , cm^{-1} : 3295 (NH); 3180, 3075 (=CH); 2975 (C_2H_5); 1600 (C=N); 1590 (C=C); 1520, 1310 (NO_2). 1H NMR spectrum (DMSO- d_6), δ , ppm: 10.34 (1H, NH), 8.12 d (2H, $H^{3',5'}$, J 7.4 Hz), 7.37 s (1H, H^5), 7.34 d (2H, $H^{2',6'}$, J 7.4 Hz), 2.69 q (2H, CH_2 , J 7.7 Hz), 1.06 t (3H, CH_3 , J 7.7 Hz). Found, %: C 45.85; H 3.85; Cl 24.61; N 14.58. $C_{11}H_{11}Cl_2N_3O_2$. Calculated, %: C 45.83; H 3.81; Cl 24.60; N 14.56.

Propyl 1,2-dichlorovinyl ketone 4-nitrophenylhydrazone (XXI) was obtained from 1.67 g (0.01 mol) of 1,2-dichlorovinyl propyl ketone and 1.53 g (0.01 mol) of 4-nitrophenylhydrazine. Yield 2.82 g (98%), mp 114–116°C. IR spectrum, ν , cm^{-1} : 3295 (NH); 3180, 3075 (=CH); 2950, 2910 (C_3H_7); 1600 (C=N); 1590 (C=C); 1520, 1310 (NO_2). 1H NMR spectrum (DMSO- d_6), δ , ppm: 10.34 (1H, NH), 8.12 d (2H, $H^{3',5'}$, J 7.4 Hz), 7.37 s (1H, H^5), 7.34 d (2H, $H^{2',6'}$, J 7.4 Hz), 2.60 t (2H, CH_2 , J 7.7 Hz), 1.59 m (2H, CH_2 , J 7.7 Hz), 1.01 t (3H, CH_3 , J 7.7 Hz). Found, %: C 47.70; H 4.34; Cl 23.47; N 13.91. $C_{12}H_{13}Cl_2N_3O_2$. Calculated, %: C 47.68; H 4.35; Cl 23.45; N 13.90.

1-Phenyl-3-alkylpyrazoles, 1-phenyl-3-alkyl-4(5)-chloropyrazoles, and 1-(4-nitrophenyl)-3-alkylpyrazoles. a. To a solution of 0.01–0.02 mol of arylhydrazine in 30–40 ml of ethanol and 0.5 ml of H_2SO_4 was added dropwise at stirring an equimolar quantity of chlorovinyl ketone. The reaction mixture was boiled for 2 h and then poured into 100 ml of water. The target pyrazole was extracted into chloroform, dichloromethane, or ether, the extract was dried with $CaCl_2$ and distilled in a vacuum; or the precipitate formed on removing the solvents was filtered off, washed with water, and dried.

b. A solution of 0.01 mol of chlorovinyl ketone arylhydrazone in 30 ml of ethanol and 0.5 ml of H_2SO_4 was boiled for 2 h and poured into water. Further workup was carried out as described above.

3-Methyl-1-phenylpyrazole (XXII). a. It was obtained from 1.05 g (0.01 mol) of methyl 2-chlorovinyl ketone and 1.08 g (0.01 mol) of phenylhydrazine. Yield 1.19 g (75%), bp 103°C (4 mm Hg), n_D^{20} 1.5870. IR spectrum, ν , cm^{-1} : 3105, 3045 (=CH); 2920 (CH_3); 1580 ($\text{C}=\text{C}$). ^1H NMR spectrum (CDCl_3), δ , ppm: 7.66 d (1H, H^5 , J 2.3 Hz), 7.54 d, 7.28 t, 7.12 t (5H, C_6H_5), 6.11 d (1H, H^4 , J 2.3 Hz). ^{13}C NMR spectrum, δ , ppm: 150.48 (C^3), 140.31 (C^1), 129.40 ($\text{C}^{3,5}$), 127.35 (C^5), 125.90 (C^4), 118.76 ($\text{C}^{2,6}$), 13.82 (CH_3). Found, %: C 75.90; H 6.40; N 17.70. $\text{C}_{10}\text{H}_{10}\text{N}_2$. Calculated, %: C 75.92; H 6.37; N 17.71.

3-Trifluoromethyl-1-phenyl-5-chloropyrazole (XXIII). a. It was obtained from 1.93 g (0.01 mol) trifluoromethyl 2,2-dichlorovinyl ketone and 1.08 g (0.01 mol) of phenylhydrazine. Yield 1.75 g (71%), bp 97°C (4 mm Hg), n_D^{20} 1.5075.

b. It was obtained from 1 g (3.5 mmol) of trifluoromethyl 2,2-dichlorovinyl ketone phenylhydrazone. Yield 0.7 g (80%). IR spectrum, ν , cm^{-1} : 3150, 3070 (=CH); 1595 ($\text{C}=\text{C}$). ^1H NMR spectrum (CDCl_3), δ , ppm: 7.48 d, 7.42 m (5H, C_6H_5), 6.60 (1H, H^4). ^{13}C NMR spectrum, δ , ppm: 143.34 q (C^3 , $J_{\text{C-F}}$ 39.2 Hz), 137.47 (C^1), 129.37 (C^5), 129.24 ($\text{C}^{3,5}$), 128.93 (C^4), 125.34 ($\text{C}^{2,6}$), 120.79 q (CF_3 , $J_{\text{C-F}}$ 269.4 Hz), 104.80 q (C^4 , $J_{\text{C-F}}$ 2.2 Hz). Found, %: C 48.72; H 2.47; Cl 14.41; N 11.39. $\text{C}_{10}\text{H}_6\text{ClF}_3\text{N}_2$. Calculated, %: C 48.70; H 2.45; Cl 14.38; N 11.36.

3-Methyl-1-phenyl-4-chloropyrazole (XXIV). a. It was prepared from 1.39 g (0.01 mol) of methyl 1,2-dichlorovinyl ketone and 1.08 g (0.01 mol) of phenylhydrazine. Yield 1.48 g (77%), bp 125°C (4 mm Hg). IR spectrum, ν , cm^{-1} : 3130, 3050 (=CH); 2950, 2920 (CH_3); 1595 ($\text{C}=\text{C}$). ^1H NMR spectrum (CDCl_3), δ , ppm: 7.76 (1H, H^5), 7.55 d, 7.37 t, 7.20 t (5H, C_6H_5), 2.28 (3H, CH_3). Found, %: C 62.30; H 4.75; Cl 18.38; N 14.52. $\text{C}_{10}\text{H}_9\text{ClN}_2$. Calculated, %: C 62.35; H 4.71; Cl 18.40; N 14.54.

3-Propyl-1-phenyl-4-chloropyrazole (XXV). a. It was prepared from 1.67 g (0.01 mol) of propyl 1,2-dichlorovinyl ketone and 1.08 g (0.01 mol) of phenylhydrazine. Yield 1.55 g (70%), bp 155°C (8 mm Hg), n_D^{20} 1.5766.

b. It was obtained from 1.5 g (5.8 mmol) of propyl 1,2-dichlorovinyl ketone phenylhydrazone. Yield 1.54 g (70%). IR spectrum, ν , cm^{-1} : 3140, 3050 (=CH); 2950, 2925, 2870 (C_3H_7); 1595 ($\text{C}=\text{C}$). ^1H NMR spectrum (CDCl_3), δ , ppm: 7.76 (1H, H^5), 7.57 d, 7.37 t, 7.21 t (5H, C_6H_5), 2.65 t (2H, CH_2 , J 7.4 Hz), 1.73 m (2H,

CH_2 , J 7.4 Hz), 0.98 t (3H, CH_3 , J 7.4 Hz). ^{13}C NMR spectrum (CDCl_3), δ , ppm: 151.46 (C^3), 139.83 (C^1), 129.41 ($\text{C}^{3,4}$), 126.36 (C^5), 124.84 (C^4), 118.59 ($\text{C}^{2,6}$), 27.89 (CH_2), 21.89 (CH_2), 13.87 (CH_3). Found, %: C 65.35; H 6.00; Cl 16.08; N 12.66. $\text{C}_{12}\text{H}_{13}\text{ClN}_2$. Calculated, %: C 65.31; H 5.99; Cl 16.06; N 12.69.

3-Methyl-1-(4-nitrophenyl)pyrazole (XXVI). a. It was obtained from 1.05 g (0.01 mol) of methyl 2-chlorovinyl ketone and 1.53 g (0.01 mol) of 4-nitrophenylhydrazine. Yield 1.83 g (90%), mp 165–166°C.

b. To the cyclization was subjected 1 g of a mixture of methyl 2-chlorovinyl ketone 4-nitrophenylhydrazone and 1-(4-nitrophenyl)-3-methylpyrazole in a ratio 1:1. Yield 0.83 g (90%). IR spectrum, ν , cm^{-1} : 3145, 3120, 3085, 3055 (=CH); 1600 ($\text{C}=\text{N}$); 1595 ($\text{C}=\text{C}$); 1535, 1320 (NO_2). ^1H NMR spectrum ($\text{DMSO}-d_6$), δ , ppm: 8.62 d (1H, H^5 , J 2.3 Hz), 8.36 d (2H, $\text{H}^{3,5}$, J 7.9 Hz), 8.08 d (2H, $\text{H}^{2,6}$, J 7.9 Hz), 6.50 (1H, H^4 , J 2.3 Hz), 2.34 (3H, CH_3). Found, %: C 59.15; H 4.43; N 20.70. $\text{C}_{10}\text{H}_9\text{N}_3\text{O}_2$. Calculated, %: C 59.11; H 4.46; N 20.68.

1-(4-Nitrophenyl)-3-propylpyrazole (XXVII). a. It was obtained from 1.33 g (0.01 mol) of propyl 2-chlorovinyl ketone and 1.53 g (0.01 mol) of 4-nitrophenylhydrazine. Yield 2.10 g (90%), mp 104–105°C. IR spectrum, ν , cm^{-1} : 3130, 3120, 3080 (=CH); 2950, 2915, 2870 (C_3H_7); 1600 ($\text{C}=\text{N}$); 1595 ($\text{C}=\text{C}$); 1525, 1320 (NO_2). ^1H NMR spectrum ($\text{DMSO}-d_6$), δ , ppm: 8.52 d (1H, H^5 , J 2.3 Hz), 8.26 d (2H, $\text{H}^{3,5}$, J 8.9 Hz), 8.00 d (2H, $\text{H}^{2,6}$, J 8.9 Hz), 6.42 (1H, H^4 , J 2.3 Hz), 2.56 t (2H, CH_2 , J 7.7 Hz), 1.61 m (2H, CH_2 , J 7.7 Hz), 0.89 t (3H, CH_3 , J 7.7 Hz). ^{13}C NMR spectrum ($\text{DMSO}-d_6$), δ , ppm: 156.58 (C^3), 144.63 (C^4), 144.54 (C^1), 129.71 (C^5), 125.79 ($\text{C}^{3,5}$), 118.24 ($\text{C}^{2,6}$), 109.01 (C^4), 30.15 (CH_2); 23.30 (CH_2); 14.13 (CH_3). Found, %: C 62.35; H 5.70; N 18.15. $\text{C}_{12}\text{H}_{13}\text{N}_3\text{O}_2$. Calculated, %: C 62.33; H 5.67; N 18.17.

1-(4-Nitrophenyl)-5-chloropyrazole (XXVIII). A solution of 2.6 g (0.01 mol) of β,β -dichloroacrolein 4-nitrophenylhydrazone in 30 g of polyphosphoric acid was heated at 130°C with stirring for 30 min. The reaction mixture was cooled, diluted with cold water, the separated precipitate was filtered off, washed, and dried. Yield 1.90 g (85%), mp 102–104°C. IR spectrum, ν , cm^{-1} : 3145, 3075 (=CH); 1600 ($\text{C}=\text{N}$); 1595 ($\text{C}=\text{C}$); 1510, 1340 (NO_2). ^1H NMR spectrum ($\text{DMSO}-d_6$), δ , ppm: 8.40 d (2H, $\text{H}^{3,5}$, J 7.2 Hz), 7.93 d (2H, $\text{H}^{2,6}$, J 7.2 Hz), 7.92 (1H, H^3 , J 1 Hz), 6.77 (1H, H^4 , J 1 Hz). ^{13}C NMR spectrum ($\text{DMSO}-d_6$), δ , ppm: 146.38 (C^4),

142.44 (C¹), 142.17 (C³), 126.61 (C⁵), 125.07 (C^{3,5}), 124.70 (C^{2,6}), 108.27 (C⁴). Found, %: C 48.35; H 2.75; Cl 15.83; N 18.80. C₉H₆ClN₃O₂. Calculated, %: C 48.34; H 2.70; Cl 15.85; N 18.79.

1-(2,4-Dinitrophenyl)-5-chloro-3-chloromethylpyrazole (XXIX) was similarly obtained from 3.53 g (0.01 mol) of 2,2-dichlorovinyl chloromethyl ketone 2,4-dinitrophenylhydrazone [16] in 40 g of polyphosphoric acid. Yield 3.01 g (95%), mp 70–72°C. IR spectrum, ν , cm⁻¹: 3145, 3075 (=CH); 2880 (CH₂Cl); 1600 (C=C); 1525, 1330 (NO₂). ¹H NMR spectrum (CDCl₃), δ , ppm: 8.90 (1H, H³), 8.62 d (1H, H⁵, *J* 8.7 Hz), 7.91 d (1H, H⁶, *J* 8.7 Hz), 6.61 (1H, H⁴), 4.57 (2H, CH₂Cl). Found, %: C 37.86; H 2.00; Cl 22.38; N 17.69. C₁₀H₆Cl₂N₄O₄. Calculated, %: C 37.88; H 1.91; Cl 22.36; N 17.67.

The study was carried out under a financial support of the Russian Foundation for Basic Research (grant no. 05-03-97202) and of Siberian Division of the Russian Academy of Sciences (interdisciplinary integration project no. 54 “Scientific fundamentals of development of new pharmaceuticals. Prospects of application of recycled raw materials”).

REFERENCES

1. Nesmeyanov, A.N., Kochetkov, N.K., and Rybinskaya, M.I., *Izv. Akad. Nauk SSSR, Ser. Khim.*, 1950, p. 350; Grandberg, I.I., *Khim. Geterotsikl. Soedin.*, 1965, p. 279.
2. Kochetkov, N.K., *Usp. Khim.*, 1955, vol. 24, p. 32.
3. Pohland, A.E. and Benson, W.R., *Chem. Rev.*, 1966, vol. 66, p. 161.
4. Bax, A. and Subramanian, S., *J. Magn. Res.*, 1986, vol. 67, p. 565.
5. Bax, A. and Subramanian, S., *J. Am. Chem. Soc.*, 1986, vol. 108, p. 2093.
6. Jeener, J., Meier, B.H., and Ernst, R.R., *J. Chem. Phys.*, 1979, vol. 69, p. 4546.
7. Polyakova, A.A. and Khmel'nitskii, R.A., *Mass-spektrometriya v organicheskoi khimii* (Mass Spectrometry in Organic Chemistry), Leningrad: Khimiya, 1972, p. 367; Zaikin, V.G., Varlamov, A.V., Mikaya, A.I., and Prostakov, N.S., *Osnovy mass-spektrometrii organicheskikh soedinenii* (Bases of Mass Spectrometry of Organic Compounds), Moscow: MAIK “Nauka/Interperiodika”, 2001, p. 285.
8. Lebedev, A.T., *Mass-spektrometriya v organicheskoi khimii* (Mass Spectrometry in Organic Chemistry), Moscow: BINOM, 2003, p. 493.
9. Kingston, D.G.I., Bursey, J.T., and Bursey, M.M., *Chem. Rev.*, 1974, vol. 74, p. 215.
10. Levkovskaya, G.G., Bozhenkov, G.V., and Mirskova, A.N., *Izbrannye metody sinteza i modifikatsii geterotsiklov* (Selected Methods of Synthesis and Heterocycle Modification), Kartsev, V.G., Ed., Moscow: IBS PRESS, 2003, vol. 2, p. 284.
11. Levkovskaya, G.G., Mirskova, A.N., Dolgushin, G.V., Larina, L.N., Ushakov, P.E., and Bozhenkov, G.V., *Zh. Org. Khim.*, 2003, vol. 39, p. 1140.
12. Bozhenkov, G.V., Levkovskaya, G.G., Larina, L.I., Ushakov, P.E., Dolgushin, G.V., and Mirskova, A.N., *Zh. Org. Khim.*, 2004, vol. 40, p. 1632.
13. Elokhina, V.N., Nakhmanovich, A.S., Larina, L.I., Shishkin, O.V., Baumer, V.N., and Lopyrev, V.A., *Izv. Akad. Nauk, Ser. Khim.*, 1999, p. 1536.
14. Ichikawa, J., Kobayashi, M., Noda, Y., Yokota, N., Amano, K., and Minami, T., *J. Org. Chem.*, 1996, 61, p. 2763.
15. Kalikhman, I.D., Levkovskaya, G.G., Lavlinskaya, L.I., Mirskova, A.N., and Atavin, A.S., *Izv. Akad. Nauk SSSR, Ser. Khim.*, 1973, p. 2235.
16. Kalikhman, I.D., Lavlinskaya, L.I., Levkovskaya, G.G., Mirskova, A.N., Atavin, A.S., and Pestunovich, V.A., *Izv. Akad. Nauk SSSR, Ser. Khim.*, 1974, p. 1402.
17. Bozhenkov, G.V., Levkovskaya, G.G., Mirskova, A.N., and Larina, L.I., *Khim. Geterotsikl. Soedin.*, 2005, p. 1012.